

SURFACE MOUNT TANTALUM CAPACITORS

QUICK REFERENCE SERIES GUIDE

SAJ SERIES BASIC RANGE

SAJ SERIES RATINGS AND CASE CODES

CAPACITANCE		RATED VOLTAGE DC at 85 °C															
CODE	µF	4V		6.3V		10V		16V		20V		25V		35V		50V	
		STD	EXT	STD	EXT	STD	EXT	STD	EXT	STD	EXT	STD	EXT	STD	EXT	STD	EXT
104	0.1										A2			A		A	
154	0.15										A2			A		B	A
224	0.22										A2			A		B	
334	0.33										A2			A		B	
474	0.47										R, A2	A		B	A	C	B
684	0.68								R, A2	A	A2	A		B	A	C	
105	1.0						R, A2	A	A2	A	B2	B	A	B	A	C	
155	1.5				R, A2	A	A2	A		A, B2	B	A	C	B	D2, D	C	
225	2.2		R, A2	A	A2	A		B	A, B2	B	A, B2	B	C	B*	D2, D	C	
335	3.3	A	A2	A			A, B2	B	A, B2	B		C	B	C	D	D2	
475	4.7	A			A, B2	B	A, B2	B		C	B, H	C		D2, D	C	D	
685	6.8		A, B2	B	A, B2	B	A	C	B, H, C2	C	B, C2	D	C	D2, D	C	E*	
106	10	B	A, B2	B	A	C	B, H, C2	C	B, C2*	D	C	D2, D	C	D	D2	E*	
156	15	B	A	C	B, H, C2	C	B, H, C2			C	D2, D	C	D	D2		E	
226	22	C	B, H, C2	C	B, H, C2		B, C	D2, D	C	D	D2		D2, D		E		
336	33	C	B, H, C2		B, C	D2, D	C	D	D2		D2, D		E				
476	47		B, C	D2, D	C	D	D2		D2, D		E						
686	68	D2, D	C	D	D2		D2, D	E	D		E						
107	100	D	D2	D	D2	E	D		E								
157	150		D2, D	E	D		E										
227	220	E	D		E		E*										
337	330		E*		E*												

SAJ SERIES

Tantalum chip capacitors covering the standard and extended ranges. Also includes miniature and low profile capacitors for special applications.

Excellent heat resistance characteristics makes it suitable for all types of soldering techniques.

Polarity indication on product and carrier tape packing for easy orientation.

Consistent molded shape and flat top surface allows accurate and fast pick and place on all popular high speed machines.

STD = STANDARD RANGE.
EXT = EXTENDED RANGE & SPECIAL SIZES.
* = CONSULT FACTORY

SAH SERIES HIGH RELIABILITY RANGE

SAH SERIES RATINGS AND CASE CODES

CAPACITANCE		RATED VOLTAGE DC at 85 °C								
CODE	µF	4V	6.3V	10V	16V	20V	25V	35V	50V	
104	0.1								A	A
154	0.15								A	B
224	0.22								A	B
334	0.33								A	B
474	0.47						A		B	C
684	0.68					A			B	C
105	1.0				A				B	C
155	1.5			A			B		C	D2, D
225	2.2		A			B			C	D2, D
335	3.3	A			B				C	
475	4.7			B			C		D2, D	
685	6.8		B			C			D2, D	
106	10	B			C		D2, D			
156	15			C		D2, D				
226	22		C		D2, D					
336	33	C		D2, D						
476	47		D2, D							
686	68	D2, D								

SAH SERIES - A special range of tantalum chip capacitors developed for high reliability applications. High heat resistance and reliability. **Humidity:** 85% RH at 85°C for 500 Hrs. **Resistance to Heat:** 125°C with derated voltage for 2000 Hrs. 150°C steady state for 1000 hrs. Plus all standard features of SAJ Series.

NOTE: SHARMA reserves the option to supply parts of a higher voltage rating and/or closer capacitance tolerance as substitutes for the parts ordered.

SAL SERIES LOW ESR RANGE

SAL SERIES RATINGS AND CASE CODES

CAPACITANCE		RATED VOLTAGE DC at 85 °C					
CODE	µF	6.3V	10V	16V	20V	25V	35V
106	10						D
156	15						D
226	22					D	D
336	33			D	D	E	
476	47			D	E		
686	68		D	E	E		
107	100	D	D	E			
157	150	E	E				
227	220	E	E*				
337	330	E*					

SAL SERIES

A special range of Tantalum Chip Capacitors in case sizes "D" and "E" designed to cover high capacitance values with low losses. This Series is suitable for special application requiring Low ESR, DF and DC leakage current and High Ripple Current carrying capability. Plus all standard features of SAJ Series.

SAF SERIES FUSED RANGE

SAF SERIES RATINGS AND CASE CODES

CAPACITANCE		RATED VOLTAGE DC at 85 °C					
CODE	µF	10V	16V	20V	25V	35V	50V
105	1.0					B	C
155	1.5					B	C
225	2.2			B		C	D2
335	3.3		B			C	D2, D
475	4.7	B			C	D2	F
685	6.8			C	D2	D2, D	
106	10		C	D2	D2, D	F	
156	15	C	D2	D2, D	F		
226	22	D2	D2, D	D, F			
336	33	D2, D	D, F	F			
476	47	D2, F	F				
686	68	F					

SAF SERIES

Special tantalum chip capacitors with internal fuse for use in circuit designs with built-in safety features. These capacitors aid in preventing smoke or fire in case of abnormal voltage or current conditions. **Distinct fusing characteristic** for given case size. Plus all standard features of SAJ Series.



PART NUMBERING & ORDERING INFORMATION

Example below indicates: SAJ Series, B Case Size, 10µF, 10% Tol., 16 Volts, 7" Reel (-) orientation, 2000 pcs/reel.

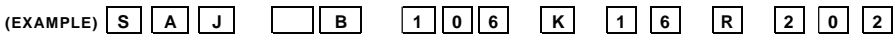

Series
Series Code: SAJ, SAL, SAH, SAF

Case Code
Case Code:

Case Code	R	A2	A	B2	B	H
EIA Code	2012	3216L	3216	3528L	3528	4726

Case Code	C2	C	D2	D	E	F
EIA Code	6032L	6032	6045	7343	7343H	7358

Capacitance

3 Digit Capacitance Code:

Capacitance µF	Code	Capacitance µF	Code
0.1	104	6.8	685
0.15	154	10	106
0.22	224	15	156
0.33	334	22	226
0.47	474	33	336
0.68	684	47	476
1.0	105	68	686
1.5	155	100	107
2.2	225	150	157
3.3	335	220	227
4.7	475	330	337

First Two Digits Represent Significant Figures of Capacitance in Picofarads.
Third Digit Indicates Number of Zeros

Tolerance

Capacitance Tolerance Code:

Capacitance Tolerance	± 20%	± 10%	±5%
Code	M	K	J

Rated Voltage

2 Digit Voltage Code:

Rated Voltage	4V	6.3V	10V	16V	20V	25V	35V	50V
Code	04	06	10	16	20	25	35	50

Product Orientation & Reel Pack Spec Code

Code	REEL Dia. mm (inch)	Product Orientation
R	178 (7)	Negative (-) side to the feed hole
L	178 (7)	Positive (+) side to the feed hole
P	330 (13)	Negative (-) side to the feed hole
N	330 (13)	Positive (+) side to the feed hole
B		BULK

Standard Reel Pack Quantity Code

7" Reel (178mm)

Case Code	R	A2	A	B2	B	H	C2	C	D2	D	E	F
Reel Qty Code	302	302	202	302	202	202	501	501	501	501	401	401
Reel Quantity	3000	3000	2000	3000	2000	2000	500	500	500	500	400	400

13" Reel (330mm)

Case Code	R	A2	A	B2	B	H	C2	C	D2	D	E	F
Reel Qty Code	103	153	902	103	802	802	302	302	252	252	152	152
Reel Quantity	10000	15000	9000	10000	8000	8000	3000	3000	2500	2500	1500	1500

RoHS Compliant

SHARMA ELECTRO COMP., reserves the right to make, from time to time, such departures from the detail specifications as may be required to permit improvements in the design of its products. The information included herein is believed to be accurate and reliable. However, SHARMA ELECTRO COMP., assume no responsibility for its use; nor for any infringements of patents or other rights of third parties which may result from its use.

PART MARKING: Parts will be marked by one of two methods shown below.

Method 1

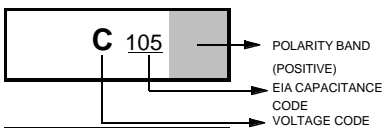

VOLTS	CODE
4	G
6.3	J
10	A
16	C
20	D
25	E
35	V
50	T

VARIATIONS:
• POLARITY ON LEFT SIDE AND MARKING RIGHT SIDE UP ALLOWED.
• "SH" BRAND AND DATE CODE OMISSIONS ALLOWED.

Voltage Code Omissions Allowed for Small Case Sizes

Method 2

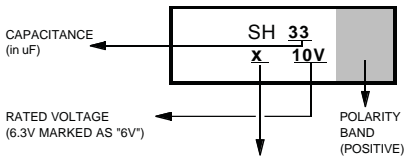

The DATE CODE may be used if space permits.

YEAR	JANUARY-- DECEMBER
1992	n p q r s t u v w x y z
1993	A B C D E F G H J K L M
1994	N P Q R S T U V W X Y Z
1995	a b c d e f g h i j k l m

Example: June 1992 = "I"
The date codes will resume in the same fashion for years 1996, 1997, 1998, 1999.

OR

TWO DIGIT CODE AS PER IEC 62
Alphabetic code for the year - C for 1992, D for 1993 etc., Numeric/Alpha Code for the month 1 to 9 for January to September, O for October, N for November and D for December. Example: November 1993=DN

NOTE:
The "SH" trademark may be used if space permits.

PART MARKING ADDITIONAL OPTIONS FOR TANTALUM

Cap Value in µF	Capacitance Code	Marking Code
0.10	104	A5
0.15	154	E5
0.22	224	J5
0.33	224	N5
0.47	474	S5
0.68	684	W5
1.0	105	A6
1.5	155	E6
2.2	225	J6
3.3	335	N6
4.7	475	S6
6.8	685	W6
10	106	A7
15	156	E7
22	226	J7
33	336	N7
47	476	S7
68	686	W7

Voltage V DC	Voltage Code
4	G
7	J
10	A
16	C
20	D
25	E
35	V

PERFORMANCE CHARACTERISTICS

ELECTRICAL - BASIC PARAMETERS

1.1 RATED CAPACITANCE

The nominal or rated value of the capacitor is measured at 25°C in a measuring bridge with 120 Hz source, free of harmonics, with 2.2V DC bias max. Capacitance is temperature and frequency dependent. Please refer to relevant series for the capacitance range covered. Nature of temperature and frequency dependence of capacitance is explained in sections 2.3 and 2.4 respectively.

1.2 CAPACITANCE TOLERANCE

The permitted variation of actual value from the nominal value is termed the tolerance. The tolerance is expressed in percentage. Please refer to relevant series for standard tolerances in which the component is available.

1.3 RATED VOLTAGE

This is the DC Voltage at which the capacitor can operate continuously up to a temperature of 85 °C. Values are listed under different voltages in each series.

1.4 CATEGORY VOLTAGE (FIG. 1.4)

The maximum voltage that may be applied continuously over the temperature range is termed the category voltage. This is the same as the rated voltage up to 85°C. After this and up to 125°C, linear derating of 2/3 rated voltage must be applied. Maximum permissible voltage at any temperature in this range follows the relation given below.

$$V_{max} = \left(1 - \frac{T-85}{120}\right) \times VR$$

V_{max} - Derated voltage at any temperature in the 85° to 125°C range
VR - Rated voltage

T - Temperature in degrees centigrade in the 85° to 125°C range

This is also illustrated in FIGURE 1.4 below;

FIGURE 1.4

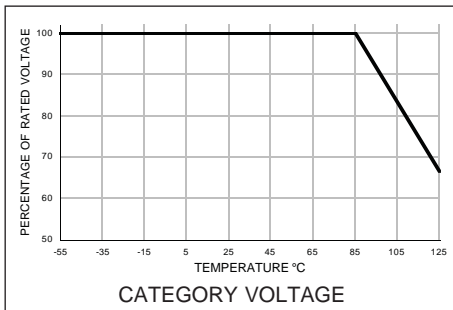

1.5 OPERATING TEMPERATURE

This is the temperature, within the range of -55° to +125°C, at which the component can function. Please refer to relevant sections for derating particulars for operating above 85°C.

1.6 DISSIPATION FACTOR

This is the measurement of tangent of loss angle (tan δ) and is expressed as a percentage. Measurement of dissipation factor is carried out at 25°C and 120 Hz with 2.2 V DC bias max. with an AC voltage, free of harmonics. Value of dissipation factor is temperature and frequency dependent. Nature of temperature and frequency dependence of dissipation factor is explained in sections 2.5 and 2.6 respectively. Quality factor Q is the reciprocal of dissipation factor.

1.7 EQUIVALENT SERIES RESISTANCE

Resistance of the component, contacts and the parallel current path etc., within a capacitor contribute to the resistance losses in the actual capacitor. These losses are considered the net Equivalent Series Resistance (ESR) of the capacitor. Measured at 25°C and 100 KHz, ESR is frequency and temperature dependent.

The electrical relation of ESR to other parameters is given below:

$$ESR = \frac{\tan \delta}{\omega C}$$

$$\omega = 2\pi f$$

$$ESR = \frac{\tan \delta}{2\pi f C}$$

ESR - Equivalent Series Resistance in ohms

f - Frequency in Hz.

C - Capacitance in farads

1.8 DC LEAKAGE CURRENT

DC leakage current is the current that flows through a capacitor at rated voltage, after the initial charging period. DC leakage current is measured at 25°C, after applying rated voltage through a 1 KΩ protective resistance for 3 minutes. Leakage current is voltage and temperature dependent.

1.9 IMPEDANCE (Z)

Impedance is the ratio of voltage to current at any given frequency. The capacitance, the resistance of the semi conducting layer and the inductance of the electrodes and leads influence the impedance of a tantalum electrolytic capacitor. The Impedance is measured at 100 KHz., at 0.5 V rms and 25°C. Impedance is frequency dependent.

1.10 SURGE VOLTAGE

The highest voltage that the capacitor may be subjected to, for short periods of time, is the surge voltage. A period of 30 seconds at a time and up to 10 times in an hour is considered the maximum allowable. Surge voltage handling capacity should not be used as a parameter in the design of circuits if the capacitor has to be periodically charged and discharged but rather should be considered a built-in safety parameter. Please refer to relevant series rating tables for surge voltage values.

ELECTRICAL - EFFECTS AND RELATIONS

2.1 EFFECT OF SURGES

Like most other electrolytic capacitors the solid tantalum electrolytics have only limited ability to handle surges (15 to 30% of rated voltage). The component must be designed to ensure that the voltage across the capacitor does not exceed the surge voltage rating at any time. Short duration spikes can also cause damage. This is all the more important in low impedance circuits where the capacitor is likely to get the full impact of surges. If such situations are expected, a higher voltage rated capacitor should be considered. Please refer to rating and case code table for the relevant series to choose alternate components.

2.2 REVERSE VOLTAGE AND NON-POLAR OPERATIONS

Solid tantalum capacitors are not designed for non-polar or reverse voltage applications. However if such situations arise in the circuit, which are not continuous in nature, the peak rated voltage applied must not exceed:

1. 10% of rated DC voltage at 25°C or 1 V whichever is less
2. 3% of rated DC voltage at 85°C or 0.5 V whichever is less.
3. 1% of category DC working voltage or 0.1 V at 125°C whichever is less.

2.3 TEMPERATURE DEPENDENCE OF CAPACITANCE (FIG. 2.3)

Capacitance of a tantalum electrolytic capacitor varies with temperature. The variation depends upon rated voltage and capacitor size. Typical change of capacitance with temperature is shown in FIGURE 2.3

FIGURE 2.3

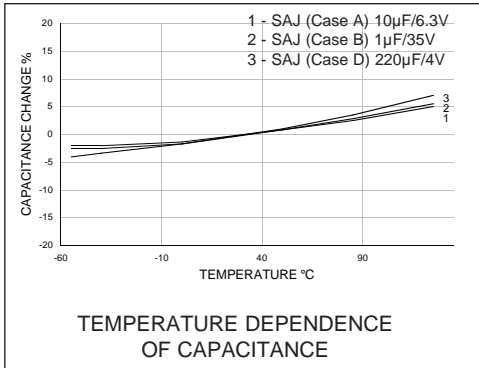

2.4 FREQUENCY DEPENDENCE OF CAPACITANCE (FIG. 2.4)

As the frequency goes up the effective capacitance comes down. Above 100 KHz the capacitance drops rapidly until resonance is reached. FIGURE 2.4 shows the typical variation of capacitance with frequency.

FIGURE 2.4

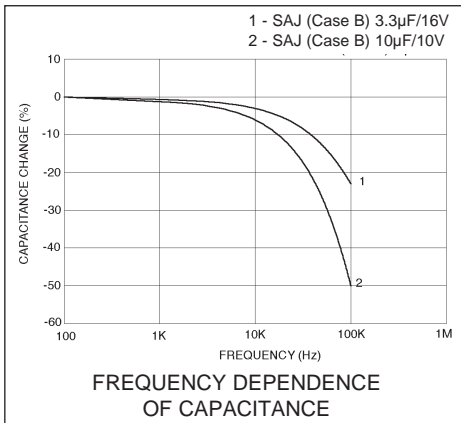

2.5 TEMPERATURE DEPENDENCE OF DISSIPATION FACTOR (FIG 2.5)

Dissipation factor varies with temperature. The minimum values of dissipation factor are achieved in the temperature range of 0 to 20°C. The variation pattern of dissipation factor with temperature for typical values is shown in FIGURE 2.5

FIGURE 2.5

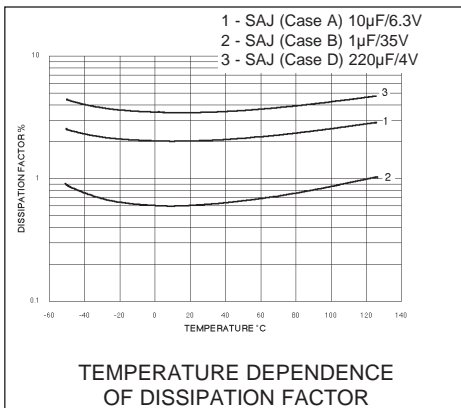

2.6 FREQUENCY DEPENDENCE OF DISSIPATION FACTOR (FIG. 2.6)

Dissipation Factor increases with frequency. The normal effect of frequency on typical values. see FIGURE 2.6

FIGURE 2.6

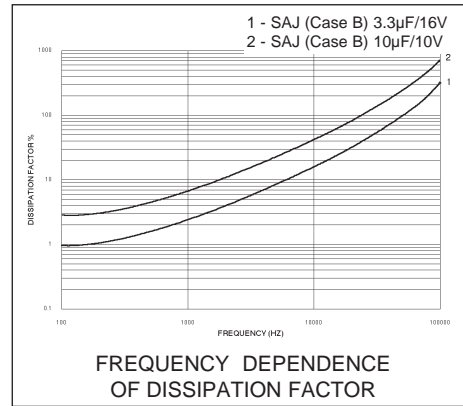

ELECTRICAL - EFFECTS AND RELATIONS

2.7 TEMPERATURE DEPENDENCE OF IMPEDANCE & ESR (FIG. 2.7)

Impedance and ESR are identical at 100 KHz. and decrease with increase in temperature. FIGURE 2.7 shows typical curves for selected values.

FIGURE 2.7

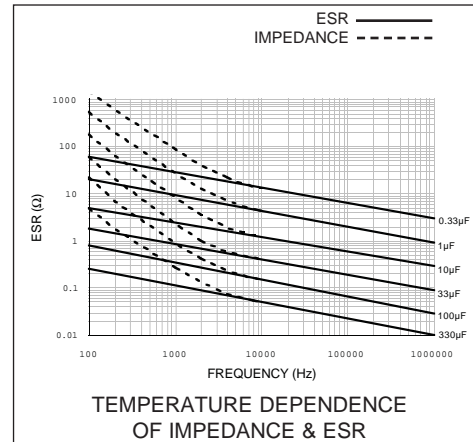

2.8 FREQUENCY DEPENDENCE OF IMPEDANCE AND ESR (FIG. 2.8)

Impedance and ESR are both inversely proportional to frequency. Impedance increases more rapidly at lower frequencies as extra contribution to impedance, due to resistance of semiconducting layer, becomes predominant. FIGURE 2.8 shows the variation for typical values.

FIGURE 2.8

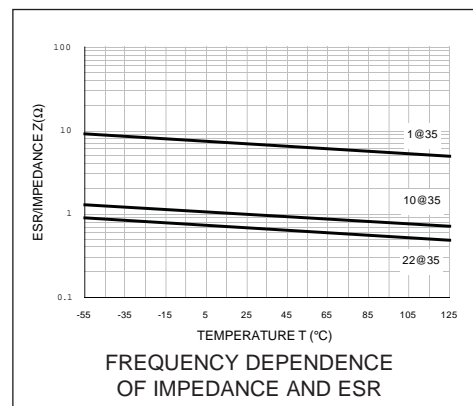

2.9 TEMPERATURE DEPENDENCE OF LEAKAGE CURRENT (FIG. 2.9)

Leakage current increases as the temperature goes up. The variation pattern of leakage current for a typical component is shown in FIGURE 2.9.

FIGURE 2.9

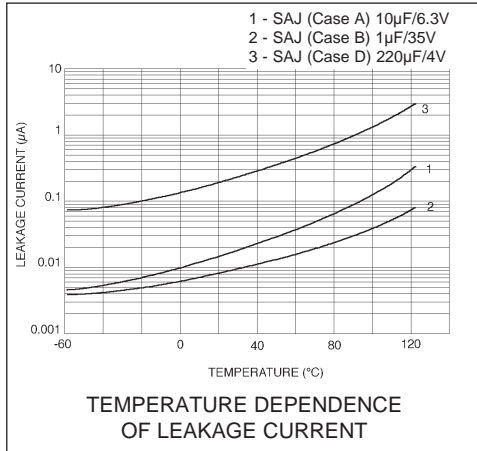

2.10 VOLTAGE DEPENDENCE OF LEAKAGE CURRENT (FIG 2.10)

The DC leakage current is reduced when applied voltage is reduced from the rated voltage. The pattern of reduction of leakage current with reduction of applied voltage, for a typical component, is shown in FIGURE 2.10. This feature can be used for derating a component to ensure higher reliability.

FIGURE 2.10

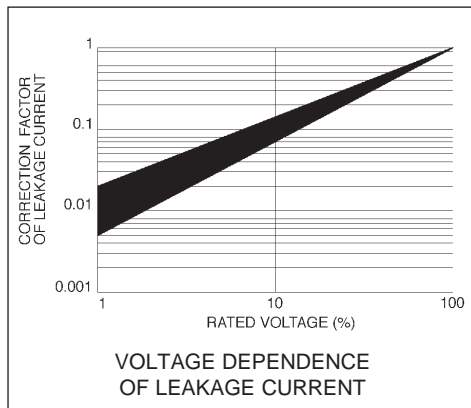

ELECTRICAL - RIPPLE RATINGS

3.1 RIPPLE RATINGS

When a capacitor is used in an AC circuit, the component becomes heated from within. The heat generated depends upon the signal form, amplitude and frequency of the AC signal, the ESR and the power dissipation capability of the component.

3.2 RIPPLE VOLTAGE AND RIPPLE CURRENT

The maximum permissible AC ripple voltage that may be applied on the chip tantalum capacitor is limited by the following criteria.

1. The peak AC voltage plus the DC bias voltage should be within the voltage rating of the capacitor.
2. The negative peak AC voltage, along with the DC bias voltage, should not exceed DC voltage rating specified in section 1.4
3. The power dissipated in the capacitor should be within the value specified in Table 1.

**TABLE 1
POWER DISSIPATION RATINGS**

Case Size	Max Power Dissipation (W)
R	0.040
A2	0.060
A	0.070
B2	0.070
B	0.080
H	0.085
C2	0.090
C	0.110
D2	0.145
D	0.150
E	0.165
F	0.165

The actual power dissipation in a capacitor follows the relation:

$$P = I^2 R \quad I = \frac{E}{Z} \quad P = \frac{E^2}{Z^2} R$$

Where;

- I = Ripple current rms - amperes
- R = Equivalent Series Resistance in ohms
- E = Ripple voltage rms in volts
- P = Power dissipated in watts
- Z = Impedance at relevant frequency in ohms

From the above relation the maximum allowable ripple voltage rms will be:

$$E = Z \sqrt{\frac{P}{R}}$$

The value of maximum ripple voltage refers to operating temperature of 25°C. For operations at temperatures above 25°C the maximum allowable ripple voltage must be derated as follows:

- Erms (50°C) - 0.7x Erms at 25°C
- Erms (85°C) - 0.5x Erms at 25°C

3.3 MAXIMUM PERMISSIBLE POWER DISSIPATION

The maximum permissible power dissipation depends on the construction of the component as well as the case size. The values at 25°C for different case sizes are listed in Table 1. As the power dissipation capability of the component depends on the ambient temperature it has to be derated for operations above 25°C. Derating factors for different temperatures are furnished in Table 2. In actual application, factors such as circuit layout, signal wave form, ventilation etc.. will affect the power dissipation capabilities significantly. To ensure that the components are functioning within the temperature range, it is recommended to measure the temperature differential between the component and the ambient. The temperature differential must be maintained below 8°C up to 85°C and below 2°C between 85°C and 125°C.

MECHANICAL CHARACTERISTICS

4.1 RESISTANCE TO SOLVENTS

When cleaned with Trichloroethene or Freon as a solvent in an ultrasonic cleaner with a frequency of 45 KHz and an output power of 500 watts, the specimen shall have legible markings and no remarkable abnormality after 5 minutes of cleaning. After immersing the sample into Trichloroethene solvent at room temperature for 60±10seconds and exposing it for 4 hours to room temperature, the values of leakage current and dissipation factor will be within the initial values. The capacitance shall be within ±3% of the initial value and there will be no abnormality in the appearance.

4.2 TERMINAL STRENGTH (FIG. 4.2)

A sample soldered to a base plate is pushed sideways horizontally with 1.5 Kg force as shown in Figure 4.2. It shall withstand the test with no evidence of mechanical degradation of terminals or the capacitor body.

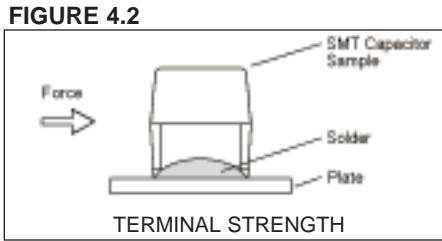

4.3 SOLDERABILITY

Terminals of the capacitor being tested are immersed in the methanol (JIS K 1501) - rosin (JIS K 5902) solution at room temperature for 5 to 10 seconds and then dipped in a molten solder (JIS Z 3282, H63A) bath at 230±5°C for 2±1sec. When removed, a minimum of 3/4 of the circumferential surface of the termination shall be covered with new solder.

4.4 VIBRATION

During the vibration test, capacitor samples will be subjected to vibration cycles consisting of 10 to 55 Hz and returning to 10 Hz in one minute with a total excursion of 1.5 mm. The vibration test shall be carried out on all three planes for a period of two hours per plane. When electrical tests are carried out in each plane, the values of leakage current and dissipation factor shall remain within the initial values. Capacitance shall be within ±5% of the initial value and the markings shall remain legible with no abnormalities in appearance.

ENVIRONMENTAL DATA

5.1 RESISTANCE TO MOISTURE

Capacitor samples will be subjected to temperature cycling at 90% to 95 % relative humidity, from +25°C to +65°C and then to +25°C over a period of 8 hours. This cycle will be repeated for 1000 hours. After the test the values of leakage current and dissipation factor shall remain within the initial values. The capacitance shall remain within ±10% of the initial value.

5.2 RESISTANCE TO HUMIDITY

Capacitor samples will be exposed to 85% relative humidity and +85°C at full rated voltage for 1000 hours. After the test the leakage current shall not exceed two times the initial specified limit and the dissipation factor shall not exceed 1.5 times the initial specification. The capacitance shall remain within ±10% of the initial value.

RELIABILITY DATA

6.1 RELIABILITY

Solid tantalum capacitors do not show any wear during actual use. They also show a consistently decreasing failure rate during life test. However random failures can happen during operation. The three important operating conditions which influence failure are:

1. Operating voltage
2. Operating temperature
3. Circuit impedance

As the voltage and temperature decrease, the failure rate reduces. Failure rate also reduces with increase in circuit impedance. Operation reliability generally improves under these conditions.

6.2 FAILURE RATE

Standard solid tantalum capacitors conform to a failure rate of 1% per 1000 hrs. This corresponds to level M reliability. The high reliability series (SAH) has a reduced failure rate of 0.5% per 1000 hrs. These figures are to be considered as the base failure rate. The effect of actual operating conditions on failure rate is explained in sections 6.3 - 6.5

6.3 EFFECT OF VOLTAGE DERATING ON FAILURE RATE (FIG. 6.3)

When a capacitor with a higher rating is used in a circuit with a maximum operating voltage less than the rated voltage, it is known as voltage derating. By reducing the operating voltage below the rated voltage the failure rate can be reduced. The relation between failure rate and voltage derating (expressed as a ratio of applied to rated voltage) is shown in the Figure 6.3. The correction factor F(V) for any operating voltage, below the rated voltage can be obtained from this graph.

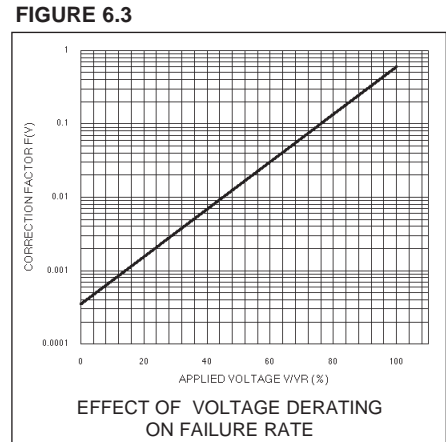

6.4 EFFECT OF TEMPERATURE DERATING ON FAILURE RATE (FIG. 6.4)

When a solid tantalum capacitor is operated at temperatures below the rated temperature the failure rate reduces and the operating reliability improves. The correction factor F(T) for any operating temperature can be obtained from the Figure 6.4

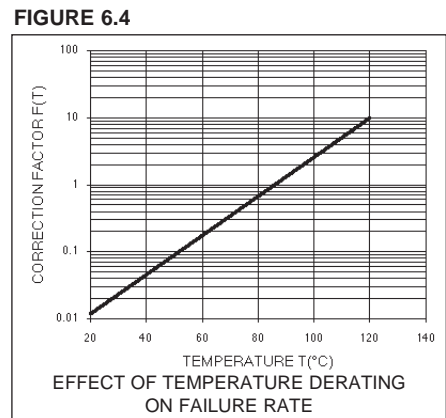

6.5 EFFECT OF CIRCUIT IMPEDANCE ON FAILURE RATE (FIG. 6.5)

As low circuit impedance causes an increase in failure rate, a series resistance is always recommended. As the circuit impedance increases the operating reliability improves. The minimum circuit impedance required is 0.1 ohms per volt or 3 ohms max. The recommended circuit impedance is 1 ohm per volt. The correction factor for circuit impedance F(Z), for different values can be obtained from the Figure 6.5

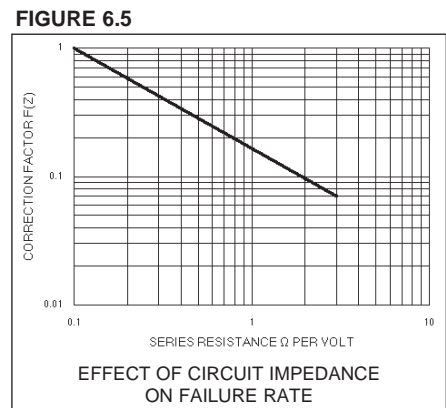

SAJ SERIES

INTRODUCTION

The SAJ series Tantalum Chip Capacitors cover a wide range of values and applications. The Extended range of this series cover higher capacitance values in smaller case sizes. Also included are low profile capacitors developed for special applications where height is critical.

FEATURES:

- HIGH SOLDER HEAT RESISTANCE - 269°C, 5 TO 10 SECS.
- ULTRA COMPACT SIZES IN EXTENDED RANGE (**BOLD PRINT**) ALLOWS HIGH DENSITY COMPONENT MOUNTING.
- LOW PROFILE CAPACITORS WITH HEIGHT 1.2MM MAX (A2 & B2) AND 1.5MM MAX (C2) FOR USE ON PCB'S, WHERE HEIGHT IS CRITICAL.
- COMPONENTS MEET IEC SPEC QC 300801/US0001 AND EIA 535BAAC. REEL PACKING STDS- EIAJ RC-1009B /EIA 481/IEC 286-3.
- EPOXY MOLDED COMPONENTS WITH CONSISTENT DIMENSIONS AND SURFACE FINISH. ENGINEERED FOR AUTOMATIC ONsertION.
- COMPATIBLE WITH ALL POPULAR HIGH SPEED ASSEMBLY MACHINES.

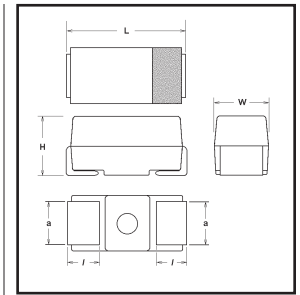

GENERAL SPECIFICATIONS

CAPACITANCE RANGE: 0.1 μ F To 330 μ F. **VOLTAGE RANGE:** 4VDC to 50VDC. **CAPACITANCE TOLERANCE:** \pm 20%(M), \pm 10%(K), (\pm 5%(J) - UPON REQUEST). **TEMPERATURE RANGE:** -55 TO +125°C WITH DERATING ABOVE 85°C. **ENVIRONMENTAL CLASSIFICATION:** 55/125/56 (IEC68-2). **DISSIPATION FACTOR:** 0.1 TO 1 μ F 4% MAX, 1.5 TO 6.8 μ F 6% MAX, 10 TO 330 μ F 8% MAX. **LEAKAGE CURRENT:** NOT MORE THAN 0.01CV μ A or 0.5 μ A WHICHEVER IS GREATER. **FAILURE RATE:** 1% PER 1000 HRS.

LIFE TEST DETAILS

CAPACITORS SHALL WITHSTAND RATED DC VOLTAGE APPLIED AT 85°C FOR 2000 HRS OR DERATED DC VOLTAGE APPLIED AT 125°C FOR 1000 HRS. AFTER THE TEST:

1. CAPACITANCE CHANGE SHALL NOT EXCEED \pm 10% OF INITIAL VALUE.
2. DISSIPATION FACTOR SHALL BE WITHIN THE NORMAL SPECIFIED LIMITS.
3. DC LEAKAGE CURRENT SHALL BE WITHIN 125% OF NORMAL LIMIT.
4. NO REMARKABLE CHANGE IN APPEARANCE. MARKINGS TO REMAIN LEGIBLE.

CASE DIMENSIONS IN MILLIMETERS (INCHES)						
CASE	EIA/IEC	L	W	H	I	a
R	2012	2.05 \pm 0.2 (0.08 \pm 0.008)	1.3 \pm 0.2 (0.05 \pm 0.008)	1.2 \pm 0.2 (0.047 \pm 0.008)	0.5 \pm 0.3 (0.020 \pm 0.012)	1.2 \pm 0.1 (0.047 \pm 0.004)
A2	3216L	3.2 \pm 0.2 (0.126 \pm 0.008)	1.6 \pm 0.2 (0.063 \pm 0.008)	1.2 \pm 0.2 (0.047 \pm 0.008)	0.7 \pm 0.3 (0.028 \pm 0.012)	1.2 \pm 0.1 (0.047 \pm 0.004)
A	3216	3.2 \pm 0.2 (0.126 \pm 0.008)	1.6 \pm 0.2 (0.063 \pm 0.008)	1.6 \pm 0.2 (0.063 \pm 0.008)	0.8 \pm 0.3 (0.032 \pm 0.012)	1.2 \pm 0.1 (0.047 \pm 0.004)
B2	3528L	3.5 \pm 0.2 (0.138 \pm 0.008)	2.8 \pm 0.2 (0.110 \pm 0.008)	1.2 \pm 0.2 (0.047 \pm 0.008)	0.7 \pm 0.3 (0.028 \pm 0.012)	1.8 \pm 0.1 (0.071 \pm 0.004)
B	3528	3.5 \pm 0.2 (0.138 \pm 0.008)	2.8 \pm 0.2 (0.110 \pm 0.008)	1.9 \pm 0.2 (0.075 \pm 0.008)	0.8 \pm 0.3 (0.031 \pm 0.012)	2.2 \pm 0.1 (0.087 \pm 0.004)
H	4726	4.8 \pm 0.2 (0.189 \pm 0.008)	2.6 \pm 0.2 (0.102 \pm 0.008)	1.8 \pm 0.2 (0.071 \pm 0.008)	0.8 \pm 0.3 (0.032 \pm 0.012)	1.8 \pm 0.1 (0.071 \pm 0.004)
C2	6032L	5.8 \pm 0.2 (0.228 \pm 0.008)	3.2 \pm 0.2 (0.126 \pm 0.008)	1.5 \pm 0.2 (0.059 \pm 0.008)	0.7 \pm 0.3 (0.028 \pm 0.012)	2.2 \pm 0.1 (0.087 \pm 0.004)
C	6032	6.0 \pm 0.3 (0.236 \pm 0.012)	3.2 \pm 0.3 (0.126 \pm 0.012)	2.5 \pm 0.3 (0.098 \pm 0.012)	1.3 \pm 0.3 (0.051 \pm 0.012)	2.2 \pm 0.1 (0.087 \pm 0.004)
D2	6045	5.8 \pm 0.3 (0.228 \pm 0.012)	4.5 \pm 0.3 (0.177 \pm 0.012)	3.1 \pm 0.3 (0.122 \pm 0.012)	1.3 \pm 0.3 (0.051 \pm 0.012)	3.1 \pm 0.1 (0.122 \pm 0.004)
D	7343	7.3 \pm 0.3 (0.287 \pm 0.012)	4.3 \pm 0.3 (0.170 \pm 0.012)	2.8 \pm 0.3 (0.110 \pm 0.012)	1.3 \pm 0.3 (0.051 \pm 0.012)	2.4 \pm 0.1 (0.095 \pm 0.004)
E	7343H (TALLER)	7.3 \pm 0.3 (0.287 \pm 0.012)	4.3 \pm 0.3 (0.170 \pm 0.012)	4.0 \pm 0.3 (0.158 \pm 0.012)	1.3 \pm 0.3 (0.051 \pm 0.012)	2.4 \pm 0.1 (0.095 \pm 0.004)



SAJ SERIES RATINGS AND CASE CODES

CAPACITANCE		RATED VOLTAGE DC at 85 °C																
CODE	μF	4V		6.3V		10V		16V		20V		25V		35V		50V		
		STD	EXT	STD	EXT	STD	EXT	STD	EXT	STD	EXT	STD	EXT	STD	EXT	STD	EXT	
104	0.1										A2			A		A		
154	0.15										A2			A		B	A	
224	0.22										A2			A		B		
334	0.33										A2			A		B		
474	0.47										R, A2	A		B	A	C	B	
684	0.68								R, A2	A	A2	A		B	A	C		
105	1.0						R, A2	A	A2	A	B2	B	A	B	A	C		
155	1.5				R, A2	A	A2	A			A, B2	B	A	C	B	D2, D	C	
225	2.2		R, A2	A	A2	A		B	A, B2	B	A, B2	B		C	B*	D2, D	C	
335	3.3	A	A2	A				A, B2	B	A, B2	B		C	B	C		D	D2
475	4.7	A			A, B2	B	A, B2	B			C	B, H	C		D2, D	C	D	
685	6.8		A, B2	B	A, B2	B	A	C	B, H, C2	C	B, C2	D	C	D2, D	C			E*
106	10	B	A, B2	B	A	C	B, H, C2	C	B, C2*	D	C	D2, D	C	D	D2			E*
156	15	B	A	C	B, H, C2	C	B, H, C2			C	D2, D	C	D	D2				E
226	22	C	B, H, C2	C	B, H, C2			B, C	D2, D	C	D	D2		D2, D				E
336	33	C	B, H, C2		B, C	D2, D	C	D	D2			D2, D		E				
476	47		B, C	D2, D	C	D	D2		D2, D			E						
686	68	D2, D	C	D	D2		D2, D	E	D			E						
107	100	D	D2	D	D2	E	D		E									
157	150		D2, D	E	D		E											
227	220	E	D		E		E*											
337	330		E*		E*													

STD = STANDARD RANGE. EXT = EXTENDED RANGE & SPECIAL SIZES. * = CONSULT FACTORY

SAJ SERIES SPECIFICATIONS

4 V DC Rated Voltage

Surge Voltage 5 V DC @ 85°C, 3.2 V DC @ 125°C

SHARMA PART NUMBER	CAP VALUE μF	DCL (MAX) μA	DF% (MAX) at+25°C	ESR(max) OHMS at 100KHz	RIPPLE (max) Irms Amps at 100 KHz
SAJ R 225 M 04 R 252	2.2	0.5	6	25.0	0.040
SAJ A2 225 M 04 R 302	2.2	0.5	6	25.0	0.043
SAJ A2 335 M 04 R 302	3.3	0.5	6	18.0	0.058
SAJ A 335 M 04 R 202	3.3	0.5	6	9.0	0.088
SAJ A 475 M 04 R 202	4.7	0.5	6	7.5	0.097
SAJ A 685 M 04 R 202	6.8	0.5	6	6.5	0.104
SAJ B2 685 M 04 R 302	6.8	0.5	6	6.5	0.104
SAJ A 106 M 04 R 202	10	0.5	6	6.0	0.108
SAJ B2 106 M 04 R 302	10	0.5	6	6.0	0.108
SAJ B 106 M 04 R 202	10	0.5	6	4.0	0.141
SAJ A 156 M 04 R 202	15	0.6	6	4.0	0.132
SAJ B 156 M 04 R 202	15	0.6	6	3.5	0.151
SAJ B 226 M 04 R 202	22	0.9	6	3.2	0.158
SAJ H 226 M 04 R 202	22	0.9	6	3.2	0.163
SAJ C2 226 M 04 R 202	22	0.9	6	3.2	0.168
SAJ C 226 M 04 R 501	22	0.9	6	2.5	0.210
SAJ B 336 M 04 R 202	33	1.3	6	2.4	0.183
SAJ H 336 M 04 R 202	33	1.3	6	2.4	0.188
SAJ C2 336 M 04 R 202	33	1.3	6	2.4	0.194
SAJ C 336 M 04 R 202	33	1.3	6	2.2	0.224
SAJ B 476 M 04 R 202	47	1.9	6	2.2	0.191
SAJ C 476 M 04 R 501	47	1.9	6	1.8	0.247
SAJ C 686 M 04 R 501	68	2.7	6	1.6	0.262
SAJ D2 686 M 04 R 501	68	2.7	6	1.1	0.363
SAJ D 686 M 04 R 501	68	2.7	6	1.1	0.369
SAJ D2 107 M 04 R 501	100	4.0	8	0.9	0.401
SAJ D 107 M 04 R 501	100	4.0	8	0.9	0.408
SAJ D2 157 M 04 R 501	150	6.0	8	0.7	0.455
SAJ D 157 M 04 R 501	150	6.0	8	0.7	0.463
SAJ D 227 M 04 R 501	220	8.8	8	0.7	0.463
SAJ E 227 M 04 R 401	220	8.8	8	0.6	0.524
SAJ E* 337 M 04 R 401	330	13.2	8	0.6	0.524

6 V DC Rated Voltage

Surge Voltage 8 V DC @ 85°C, 5 V DC @ 125°C

SHARMA PART NUMBER	CAP VALUE μF	DCL (MAX) μA	DF% (MAX) at+25°C	ESR(max) OHMS at 100KHz	RIPPLE (max) Irms Amps at 100 KHz
SAJ R 155 M 06 R 252	1.5	0.5	6	25.0	0.040
SAJ A2 155 M 06 R 302	1.5	0.5	6	25.0	0.049
SAJ A2 225 M 06 R 302	2.2	0.5	6	20.0	0.055
SAJ A 225 M 06 R 202	2.2	0.5	6	9.0	0.088
SAJ A 335 M 06 R 202	3.3	0.5	6	7.5	0.097
SAJ A 475 M 06 R 202	4.7	0.5	6	6.5	0.104
SAJ B2 475 M 06 R 302	4.7	0.5	6	6.5	0.104

6 V DC Rated Voltage - Continued

Surge Voltage 8 V DC @ 85°C, 5 V DC @ 125°C

SHARMA PART NUMBER	CAP VALUE μF	DCL (MAX) μA	DF% (MAX) at+25°C	ESR(max) OHMS at 100KHz	RIPPLE (max) Irms Amps at 100 KHz
SAJ A 685 M 06 R 202	6.8	0.5	6	6.0	0.108
SAJ B2 685 M 06 R 302	6.8	0.5	6	5.0	0.118
SAJ B 685 M 06 R 202	6.8	0.5	6	4.0	0.141
SAJ A 106 M 06 R 202	10	0.6	6	4.0	0.132
SAJ B 106 M 06 R 202	10	0.6	6	3.5	0.151
SAJ B 156 M 06 R 202	15	1.0	6	3.2	0.158
SAJ H 156 M 06 R 202	15	1.0	6	3.0	0.168
SAJ C2 156 M 06 R 202	15	1.0	6	3.0	0.173
SAJ C 156 M 06 R 501	15	1.0	6	2.5	0.210
SAJ B 226 M 06 R 202	22	1.4	6	2.4	0.183
SAJ H 226 M 06 R 202	22	1.4	6	2.4	0.188
SAJ C2 226 M 06 R 501	22	1.4	6	2.4	0.224
SAJ C 226 M 06 R 501	22	1.4	6	2.2	0.224
SAJ B 336 M 06 R 202	33	2.1	6	2.2	0.191
SAJ C 336 M 06 R 501	33	2.1	6	1.8	0.247
SAJ C 476 M 06 R 501	47	3.0	6	1.6	0.262
SAJ D2 476 M 06 R 501	47	3.0	6	1.1	0.363
SAJ D 476 M 06 R 501	47	3.0	6	1.1	0.369
SAJ D2 686 M 06 R 501	68	4.3	6	0.9	0.401
SAJ D 686 M 06 R 501	68	4.3	6	0.9	0.408
SAJ D2 107 M 06 R 501	100	6.0	8	0.8	0.426
SAJ D 107 M 06 R 501	100	6.0	8	0.8	0.433
SAJ D 157 M 06 R 501	150	9.0	8	0.8	0.433
SAJ E 157 M 06 R 401	150	9.0	8	0.6	0.524
SAJ E 227 M 06 R 401	220	13.2	8	0.6	0.524
SAJ E* 337 M 06 R 401	330	19.8	8	0.6	0.524

10 V DC Rated Voltage

Surge Voltage 13 V DC @ 85°C, 8 V DC @ 125°C

SHARMA PART NUMBER	CAP VALUE μF	DCL (MAX) μA	DF% (MAX) at+25°C	ESR(max) OHMS at 100KHz	RIPPLE (max) Irms Amps at 100 KHz
SAJ R 105 M 10 R 252	1	0.5	4	25.0	0.040
SAJ A2 105 M 10 R 302	1	0.5	4	25.0	0.049
SAJ A2 155 M 10 R 302	1.5	0.5	6	20.0	0.055
SAJ A 155 M 10 R 202	1.5	0.5	6	10.0	0.084
SAJ A 225 M 10 R 202	2.2	0.5	6	7.5	0.097
SAJ A 335 M 10 R 202	3.3	0.5	6	6.5	0.104
SAJ B2 336 M 10 R 302	3.3	0.5	6	6.5	0.104
SAJ A 475 M 10 R 202	4.7	0.5	6	6.0	0.108
SAJ B2 475 M 10 R 302	4.7	0.5	6	6.0	0.141
SAJ B 475 M 10 R 202	4.7	0.5	6	4.0	0.141
SAJ A 685 M 10 R 202	6.8	0.7	6	4.0	0.132
SAJ B 685 M 10 R 202	6.8	0.7	6	3.5	0.151
SAJ B 106 M 10 R 202	10	1.0	6	3.2	0.158

NOTE: EXTENDED RANGE & SPECIAL CASE SIZES SHOWN IN BOLD. FOR 10% TOLERANCE CHANGE TOLERANCE CODE FROM M TO K. FOR 5% TOLERANCE CHANGE TOLERANCE CODE FROM M TO J. STANDARD REEL SIZE AND ORIENTATION = R. FOR OTHER SEE ORDERING INFORMATION ON PAGE 3. * = CONSULT FACTORY.



10 V DC Rated Voltage - Continued

Surge Voltage 13 V DC @ 85°C, 8 V DC @ 125°C

Table with 7 columns: SHARMA PART NUMBER, CAP VALUE (µF), DCL (MAX) (µA), DF% (MAX) at+25°C, ESR(max) OHMS at 100KHz, RIRPLE (max) Irms Amps at 100 KHz. Rows include parts like SAJ H 106 M 10 R 202, SAJ C2 106 M 10 R 202, etc.

16 V DC Rated Voltage

Surge Voltage 20 V DC @ 85°C, 13 V DC @ 125°C

Table with 7 columns: SHARMA PART NUMBER, CAP VALUE (µF), DCL (MAX) (µA), DF% (MAX) at+25°C, ESR(max) OHMS at 100KHz, RIRPLE (max) Irms Amps at 100 KHz. Rows include parts like SAJ R 684 M 16 R 252, SAJ A2 684 M 16 R 302, etc.

20 V DC Rated Voltage

Surge Voltage 26 V DC @ 85°C, 16 V DC @ 125°C

Table with 7 columns: SHARMA PART NUMBER, CAP VALUE (µF), DCL (MAX) (µA), DF% (MAX) at+25°C, ESR(max) OHMS at 100KHz, RIRPLE (max) Irms Amps at 100 KHz. Rows include parts like SAJ A2 104 M 20 R 302, SAJ A2 154 M 20 R 302, etc.

20 V DC Rated Voltage - Continued

Surge Voltage 26 V DC @ 85°C, 16 V DC @ 125°C

Table with 7 columns: SHARMA PART NUMBER, CAP VALUE (µF), DCL (MAX) (µA), DF% (MAX) at+25°C, ESR(max) OHMS at 100KHz, RIRPLE (max) Irms Amps at 100 KHz. Rows include parts like SAJ D 156 M 20 R 501, SAJ D2 226 M 20 R 501, etc.

25 V DC Rated Voltage

Surge Voltage 32 V DC @ 85°C, 20 V DC @ 125°C

Table with 7 columns: SHARMA PART NUMBER, CAP VALUE (µF), DCL (MAX) (µA), DF% (MAX) at+25°C, ESR(max) OHMS at 100KHz, RIRPLE (max) Irms Amps at 100 KHz. Rows include parts like SAJ A 474 M 25 R 202, SAJ A 684 M 25 R 202, etc.

35 V DC Rated Voltage

Surge Voltage 45 V DC @ 85°C, 28 V DC @ 125°C

Table with 7 columns: SHARMA PART NUMBER, CAP VALUE (µF), DCL (MAX) (µA), DF% (MAX) at+25°C, ESR(max) OHMS at 100KHz, RIRPLE (max) Irms Amps at 100 KHz. Rows include parts like SAJ A 104 M 35 R 202, SAJ A 154 M 35 R 202, etc.

50 V DC Rated Voltage

Surge Voltage 63 V DC @ 85°C, 40 V DC @ 125°C

Table with 7 columns: SHARMA PART NUMBER, CAP VALUE (µF), DCL (MAX) (µA), DF% (MAX) at+25°C, ESR(max) OHMS at 100KHz, RIRPLE (max) Irms Amps at 100 KHz. Rows include parts like SAJ A 104 M 50 R 202, SAJ A 154 M 50 R 202, etc.

NOTE: EXTENDED RANGE & SPECIAL CASE SIZES SHOWN IN BOLD. FOR 10% TOLERANCE CHANGE TOLERANCE CODE FROM M TO K. FOR 5% TOLERANCE CHANGE TOLERANCE CODE FROM M TO J. STANDARD REEL SIZE AND ORIENTATION = R. FOR OTHER SEE ORDERING INFORMATION ON PAGE 3. * = CONSULT FACTORY.

SAL SERIES

INTRODUCTION

The SAL Series Tantalum Chip Capacitors are designed to cover high capacitance values with low losses in case sizes "D" and "E". This Series is suitable for special application requiring Low ESR,DF and DCL.

FEATURES:

- LOW ESR, DF AND DC LEAKAGE CURRENT.
- HIGH RIPPLE CURRENT CARRYING CAPABILITY.
- HIGH SOLDER HEAT RESISTANCE - 269°C, 5 TO 10 SECS.
- COMPONENT REEL PACKING STDS- EIA-481-1 AND REELING PER IEC 286-3 IN 7" STANDARD REELS.
- EPOXY MOLDED COMPONENTS WITH CONSISTENT DIMENSIONS AND SURFACE FINISH. ENGINEERED FOR AUTOMATIC ONsertION.
- COMPATIBLE WITH ALL POPULAR HIGH SPEED ASSEMBLY MACHINES.

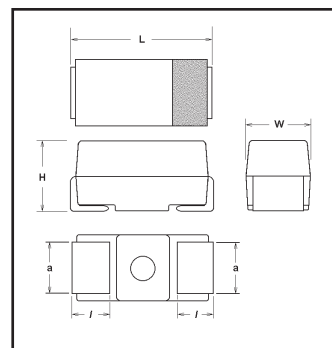

GENERAL SPECIFICATIONS

CAPACITANCE RANGE: 10 μ F To 330 μ F.

VOLTAGE RANGE: 6.3 VDC to 35 VDC.

CAPACITANCE TOLERANCE: $\pm 20\%$ (M), $\pm 10\%$ (K), ($\pm 5\%$ (J) - UPON REQUEST).

TEMPERATURE RANGE: -55 TO +125°C WITH DERATING ABOVE 85°C.

ENVIRONMENTAL CLASSIFICATION: 55/125/56 (IEC68-2).

DISSIPATION FACTOR: 10 TO 68 μ F 4% MAX, 100 TO 330 μ F 4% MAX.

LEAKAGE CURRENT: PLEASE REFER TO RATINGS TABLE ON FOLLOWING PAGE.

FAILURE RATE: 1% PER 1000 HRS.

LIFE TEST DETAILS

CAPACITORS SHALL WITHSTAND RATED DC VOLTAGE APPLIED AT 85°C FOR 2000 HRS OR DERATED DC VOLTAGE APPLIED AT 125°C FOR 1000 HRS. AFTER THE TEST:

1. CAPACITANCE CHANGE SHALL NOT EXCEED $\pm 10\%$ OF INITIAL VALUE.
2. DISSIPATION FACTOR SHALL BE WITHIN THE NORMAL SPECIFIED LIMITS.
3. DC LEAKAGE CURRENT SHALL BE WITHIN 125% OF NORMAL LIMIT.
4. NO REMARKABLE CHANGE IN APPEARANCE. MARKINGS TO REMAIN LEGIBLE.

CASE DIMENSIONS IN MILLIMETERS (INCHES)						
CASE	EIA/IEC	L	W	H	l	a
D	7343	7.3 \pm 0.3 (0.287 \pm 0.012)	4.3 \pm 0.3 (0.170 \pm 0.012)	2.8 \pm 0.3 (0.110 \pm 0.012)	1.3 \pm 0.3 (0.051 \pm 0.012)	2.4 \pm 0.1 (0.095 \pm 0.004)
E	7343H (TALLER)	7.3 \pm 0.3 (0.287 \pm 0.012)	4.3 \pm 0.3 (0.170 \pm 0.012)	4.0 \pm 0.3 (0.158 \pm 0.012)	1.3 \pm 0.3 (0.051 \pm 0.012)	2.4 \pm 0.1 (0.095 \pm 0.004)

SAL SERIES RATINGS AND CASE CODES

CAPACITANCE		RATED VOLTAGE DC at 85 °C					
CODE	μ F	6.3V	10V	16V	20V	25V	35V
106	10						D
156	15					D	E
226	22				D	D	E
336	33			D	D	E	
476	47			D	E		
686	68		D	E	E		
107	100	D	D	E			
157	150	E	D, E				
227	220	E	E*				
337	330	E*					

SAL SERIES SPECIFICATIONS

6.3 V DC Rated Voltage
Surge Voltage 8 VDC @ 85°C and 5 VDC @ 125°C

SHARMA PART NUMBER	CAP VALUE µf	CASE CODE	DCL (MAX) at25°C	DF% (MAX) at25°C	ESR (MAX) OHMS at 100 KHz.	RIPPLE(MAX) I rms Amps. at 100 KHz.
SALD107K06R501	100	D	4.8	6	0.100	1.22
SALE157K06R501	150	E	7.2	6	0.100	1.28
SALE557K06R501	220	E	10.6	6	0.100	1.28
SALE557K06R501	330	E	15.8	6	0.100	1.28

10 V DC Rated Voltage
Surge Voltage 13 VDC @ 85°C and 8 VDC @ 125°C

SHARMA PART NUMBER	CAP VALUE µf	CASE CODE	DCL (MAX) at25°C	DF% (MAX) at25°C	ESR (MAX) OHMS at 100 KHz.	RIPPLE(MAX) I rms Amps. at 100 KHz.
SALD686K10R501	68	D	5.4	4	0.175	0.93
SALD107K10R501	100	D	8.0	6	0.100	1.22
SALD157K10R501	150	D	8.0	6	0.150	1.22
SALE157K10R501	150	E	12.0	6	0.100	1.28
SALE227K10R501	220	E	17.5	6	0.100	1.28

16 V DC Rated Voltage
Surge Voltage 20 VDC @ 85°C and 12 VDC @ 125°C

SHARMA PART NUMBER	CAP VALUE µf	CASE CODE	DCL (MAX) at25°C	DF% (MAX) at25°C	ESR (MAX) OHMS at 100 KHz.	RIPPLE(MAX) I rms Amps. at 100 KHz.
SALD336K16R501	33	D	4.2	4	0.225	0.82
SALD476K16R501	47	D	6.0	4	0.175	0.93
SALE686K16R501	68	E	8.7	4	0.150	1.05
SALE107K16R501	100	E	12.6	6	0.150	1.05

20 V DC Rated Voltage
Surge Voltage 26 VDC @ 85°C and 16 VDC @ 125°C

SHARMA PART NUMBER	CAP VALUE µf	CASE CODE	DCL (MAX) at25°C	DF% (MAX) at25°C	ESR (MAX) OHMS at 100 KHz.	RIPPLE(MAX) I rms Amps. at 100 KHz.
SALD226K20R501	22	D	3.5	4	0.225	0.82
SALD336K20R501	33	D	5.3	4	0.225	0.82
SALE476K20R501	47	E	7.5	4	0.200	0.91
SALE686K20R501	68	E	10.9	4	0.200	0.91

25 V DC Rated Voltage
Surge Voltage 32 VDC @ 85°C and 20 VDC @ 125°C

SHARMA PART NUMBER	CAP VALUE µf	CASE CODE	DCL (MAX) at25°C	DF% (MAX) at25°C	ESR (MAX) OHMS at 100 KHz.	RIPPLE(MAX) I rms Amps. at 100 KHz.
SALD156K25R501	15	D	3.0	4	0.275	0.74
SALD226K25R501	22	D	4.4	4	0.250	0.77
SALE336K25R501	33	E	6.6	4	0.225	0.86

35 V DC Rated Voltage
Surge Voltage 46 VDC @ 85°C and 28 VDC @ 125°C

SHARMA PART NUMBER	CAP VALUE µf	CASE CODE	DCL (MAX) at25°C	DF% (MAX) at25°C	ESR (MAX) OHMS at 100 KHz.	RIPPLE(MAX) I rms Amps. at 100 KHz.
SALD106K35R501	10	D	2.8	4	0.300	0.71
SALE156K35R501	15	E	4.2	4	0.275	0.77
SALE226K35R501	22	E	0.2	4	0.275	0.77



SAH SERIES

INTRODUCTION

SAH Series molded tantalum chip capacitors are specially developed for High Heat Resistance and High Reliability. Ideal for automotive electronics applications.

FEATURES:

- HIGH HEAT RESISTANCE MAKES IT SUITABLE FOR ALL TYPES OF SOLDERING
- HIGH RESISTANCE TO HEAT - 125°C WITH DERATED VOLTAGE FOR 2000 HRS. 150°C STEADY STATE FOR 1000 HRS.
- HIGH RESISTANCE TO MOISTURE. 85°C & 85% RH FOR 500 HRS. 65°C 95% RH WITH RATED VOLTAGE FOR 500 HRS.
- HIGHEST RELIABILITY DUE TO EXCEPTIONALLY LOW FAILURE RATE OF 0.5% PER 1000 HRS.
- COMPONENTS MEET EIAJ RC-3813 & JIS C 5102. REEL PACKING STDS - EIAJ RC-1009B /EIA 481/IEC 286-3.
- EPOXY MOLDED COMPONENTS WITH CONSISTENT DIMENSIONS AND SURFACE FINISH. ENGINEERED FOR AUTOMATIC ONsertION.
- COMPATIBLE WITH ALL POPULAR HIGH SPEED ASSEMBLY MACHINES.

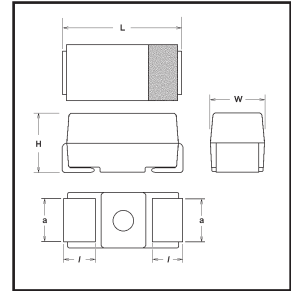

GENERAL SPECIFICATIONS

CAPACITANCE RANGE: 1.0 µF to 68 µF. **VOLTAGE RANGE:** 4VDC to 50VDC. **CAPACITANCE TOLERANCE:** ±20%(M), ±10%(K), (±5%(J) - UPON REQUEST). **TEMPERATURE RANGE** -55 TO +125°C WITH DERATING ABOVE 85°C. **ENVIRONMENTAL CLASSIFICATION:** 55/125/56(IEC68-2). **DISSIPATION FACTOR:** 0.1µF TO 1µF 4 % MAX,1.5µF TO 68 µF 6% MAX. **LEAKAGE CURRENT:** NOT MORE THAN 0.005CV µA or 0.25 µA WHICHEVER IS GREATER. **FAILURE RATE:** 0.5%PER 1000 HRS.

LIFE TEST DETAILS

CAPACITORS SHALL WITHSTAND RATED DC VOLTAGE APPLIED AT 85°C for 2000 Hrs. or DERATED DC VOLTAGE APPLIED at 125°C for 1000 Hrs. AFTER THE TEST:

1. CAPACITANCE CHANGE SHALL NOT EXCEED ±10%OF INITIAL VALUE.
2. DISSIPATION FACTOR SHALL BE WITHIN THE NORMAL SPECIFIED LIMITS.
3. DC LEAKAGE CURRENT SHALL BE WITHIN 125% OF NORMAL LIMIT.
4. NO REMARKABLE CHANGE IN APPEARANCE. MARKINGS TO REMAIN LEGIBLE.

CASE DIMENSIONS IN MILLIMETERS (INCHES)						
CASE	EIA/IEC	L	W	H	I	a
B	3528	3.5±0.2 (0.138±0.008)	2.8±0.2 (0.110±0.008)	1.9±0.2 (0.075±0.008)	0.8±0.3 (0.031±0.012)	2.2±0.1 (0.087±0.004)
C	6032	6.0±0.3 (0.236±0.012)	3.2±0.3 (0.126±0.012)	2.5±0.3 (0.098±0.012)	1.3±0.3 (0.051±0.012)	2.2±0.1 (0.087±0.004)
D2	6045	5.8±0.3 (0.228±0.012)	4.5±0.3 (0.177±0.012)	3.1±0.3 (0.122±0.012)	1.3±0.3 (0.051±0.012)	3.1±0.1 (0.122±0.004)
D	7343	7.3±0.3 (0.287±0.012)	4.3±0.3 (0.170±0.012)	2.8±0.3 (0.110±0.012)	1.3±0.3 (0.051±0.012)	2.4±0.1 (0.095±0.004)

SAH SERIES RATINGS AND CASE CODES

CAPACITANCE CODE	µF	RATED VOLTAGE DC at 85 °C								
		4V	6.3V	10V	16V	20V	25V	35V	50V	
104	0.1							A	A	
154	0.15							A	B	
224	0.22							A	B	
334	0.33							A	B	
474	0.47						A	B	C	
684	0.68					A		B	C	
105	1.0				A			B	C	
155	1.5			A			B	C	D2, D	
225	2.2		A			B		C	D2, D	
335	3.3	A			B			C		
475	4.7			B			C	D2, D		
685	6.8		B			C		D2, D		
106	10	B			C		D2, D			
156	15			C		D2, D				
226	22		C		D2, D					
336	33	C		D2, D						
476	47		D2, D							
686	68	D2, D								

*HIGH
RELIABILITY
SERIES*



SAH SERIES SPECIFICATIONS

4 V DC Rated Voltage

Surge Voltage 5 VDC @ 85°C and 3.2 VDC @ 125°C

Table with 6 columns: SHARMA PART NUMBER, CAP VALUE, DCL (MAX), DF% (MAX), ESR(max) OHMS at 100KHz, RIPPLE (max) Irms Amps at 100 KHz. Rows include SAH A, B, C, D2, D.

6.3 V DC Rated Voltage

Surge Voltage 8 VDC @ 85°C and 5 VDC @ 125°C

Table with 6 columns: SHARMA PART NUMBER, CAP VALUE, DCL (MAX), DF% (MAX), ESR(max) OHMS at 100KHz, RIPPLE (max) Irms Amps at 100 KHz. Rows include SAH A, B, C, D2, D.

10 V DC Rated Voltage

Surge Voltage 13 VDC @ 85°C and 8 VDC @ 125°C

Table with 6 columns: SHARMA PART NUMBER, CAP VALUE, DCL (MAX), DF% (MAX), ESR(max) OHMS at 100KHz, RIPPLE (max) Irms Amps at 100 KHz. Rows include SAH A, B, C, D2, D.

16 V DC Rated Voltage

Surge Voltage 20 VDC @ 85°C and 13 VDC @ 125°C

Table with 6 columns: SHARMA PART NUMBER, CAP VALUE, DCL (MAX), DF% (MAX), ESR(max) OHMS at 100KHz, RIPPLE (max) Irms Amps at 100 KHz. Rows include SAH A, B, C, D2, D.

20 V DC Rated Voltage

Surge Voltage 26 VDC @ 85°C and 16 VDC @ 125°C

Table with 6 columns: SHARMA PART NUMBER, CAP VALUE, DCL (MAX), DF% (MAX), ESR(max) OHMS at 100KHz, RIPPLE (max) Irms Amps at 100 KHz. Rows include SAH A, B, C, D2, D.

25 V DC Rated Voltage

Surge Voltage 32 VDC @ 85°C and 20 VDC @ 125°C

Table with 6 columns: SHARMA PART NUMBER, CAP VALUE, DCL (MAX), DF% (MAX), ESR(max) OHMS at 100KHz, RIPPLE (max) Irms Amps at 100 KHz. Rows include SAH A, B, C, D2, D.

35 V DC Rated Voltage

Surge Voltage 45 VDC @ 85°C and 28 VDC @ 125°C

Table with 6 columns: SHARMA PART NUMBER, CAP VALUE, DCL (MAX), DF% (MAX), ESR(max) OHMS at 100KHz, RIPPLE (max) Irms Amps at 100 KHz. Rows include SAH A, B, C, D2, D.

50 V DC Rated Voltage

Surge Voltage 63 VDC @ 85°C and 40 VDC @ 125°C

Table with 6 columns: SHARMA PART NUMBER, CAP VALUE, DCL (MAX), DF% (MAX), ESR(max) OHMS at 100KHz, RIPPLE (max) Irms Amps at 100 KHz. Rows include SAH A, B, C, D2, D.

NOTE: FOR 10% TOLERANCE CHANGE TOLERANCE CODE FROM M TO K. FOR 5% TOLERANCE CHANGE TOLERANCE CODE FROM M TO J. STANDARD REEL SIZE AND ORIENTATION = R. FOR OTHER SEE ORDERING INFORMATION ON PAGE 3.



SAF SERIES

INTRODUCTION

SAF Series molded Tantalum Chip Capacitors with Built-in fuse, are developed to provide safety to the PCB by opening the circuit in case of abnormal voltage or current.

FEATURES:

- HIGH HEAT RESISTANCE MAKES IT SUITABLE FOR ALL TYPES OF SOLDERING
- FUSE CHARACTERISTICS DESIGNED TO PREVENT FIRE OR SMOKE
- B, C & D CASE SIZES DESIGNED TO OPEN IN<100 SEC AT 1.5A OR<5SEC AT 5A. D & F CASE SIZES OPEN IN <5 SEC AT 5A. (REFERENCE GRAPH G1 FOR FUSING TIME PATTERN.)
- LOW ESR OF <2 OHMS AT 1MHZ LOW INDUCTANCE OF 5nH AT 200 MHZ.
- COMPONENTS MEET IEC SPEC QC 300801/US0001 AND EIA J RC- 3813 & JIS C 5102. REEL PACKING STDS - EIA J RC-1009B /EIA 481/IEC 286-3. EPOXY MOLDED COMPONENTS WITH CONSISTENT DIMENSIONS AND SURFACE FINISH.
- ENGINEERED FOR AUTOMATIC ONsertion.
- COMPATIBLE WITH ALL POPULAR HIGH SPEED ASSEMBLY MACHINES.

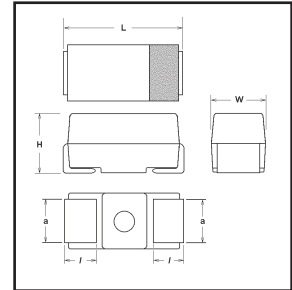

GENERAL SPECIFICATIONS

CAPACITANCE RANGE: 1.0µF to 68µF. **VOLTAGE RANGE:** 10VDC to 50VDC.
CAPACITANCE TOLERANCE: ±20%(M), ±10%(K), (±5%(J) - UPON REQUEST)
TEMPERATURE RANGE: -55 to +125°C with DERATING ABOVE 85°C
ENVIRONMENTAL CLASSIFICATION: 55/125/56(IEC68-2)
DISSIPATION FACTOR: 0.1µF to 1µF 4% Max 1.5 µF to 22 µF 5% MAX, 33µF 8% Max. **LEAKAGE CURRENT:** NOT MORE THAN 0.01CV µA or 0.5 µA WHICHEVER IS GREATER **FAILURE RATE:** 1% PER 1000 HRS.

LIFE TEST DETAILS

CAPACITORS SHALL WITHSTAND RATED DC VOLTAGE APPLIED AT 85°C FOR 2000 HRS. OR DERATED DC VOLTAGE APPLIED AT 125°C FOR 1000 HRS. AFTER THE TEST:

1. CAPACITANCE CHANGE SHALL NOT EXCEED ±10% OF INITIAL VALUE.
2. DISSIPATION FACTOR SHALL BE WITHIN THE NORMAL SPECIFIED LIMITS.
3. DC LEAKAGE CURRENT SHALL BE WITHIN 125% OF NORMAL LIMIT.
4. NO REMARKABLE CHANGE IN APPEARANCE. MARKINGS TO REMAIN LEGIBLE.

***WITH
BUILT-IN
FUSE***

GRAPH G1

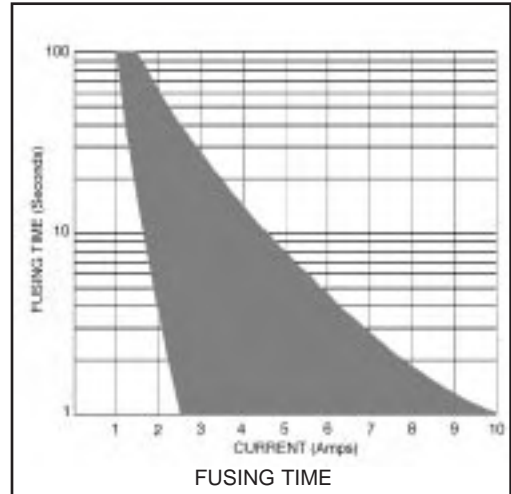

SAH SERIES RATINGS AND CASE CODES

CAPACITANCE	RATED VOLTAGE DC at 85 °C									
	CODE	µF	4V	6.3V	10V	16V	20V	25V	35V	50V
104	0.1								A	A
154	0.15								A	B
224	0.22								A	B
334	0.33								A	B
474	0.47							A	B	C
684	0.68						A		B	C
105	1.0					A			B	C
155	1.5				A			B	C	D2, D
225	2.2		A				B		C	D2, D
335	3.3	A				B			C	
475	4.7				B			C	D2, D	
685	6.8		B				C		D2, D	
106	10	B				C		D2, D		
156	15				C		D2, D			
226	22		C			D2, D				
336	33	C			D2, D					
476	47		D2, D							
686	68	D2, D								

CASE DIMENSIONS IN MILLIMETERS (INCHES)						
CASE	EIA/IEC	L	W	H	l	a
B	3528	3.5±0.2 (0.138±0.008)	2.8±0.2 (0.110±0.008)	1.9±0.2 (0.075±0.008)	0.8±0.3 (0.031±0.012)	2.2±0.1 (0.087±0.004)
C	6032	6.0±0.3 (0.236±0.012)	3.2±0.3 (0.126±0.012)	2.5±0.3 (0.098±0.012)	1.3±0.3 (0.051±0.012)	2.2±0.1 (0.087±0.004)
D	7343	7.3±0.3 (0.287±0.012)	4.3±0.3 (0.170±0.012)	2.8±0.3 (0.110±0.012)	1.3±0.3 (0.051±0.012)	2.4±0.1 (0.095±0.004)
F	7358	7.3±0.3 (0.287±0.012)	5.8±0.3 (0.228±0.012)	3.5±0.3 (0.138±0.012)	1.3±0.3 (0.052±0.012)	3.5±0.2 (0.138±0.008)



SAF SERIES SPECIFICATIONS

10 V DC Rated Voltage
Surge Voltage 13 VDC @ 85°C
and 8 VDC @ 125°C

SHARMA PART NUMBER					CAP VALUE µF	DCL (MAX) µA	DF% (MAX) AT +25°C	ESR(max) at 100 KHz OHMS	RIPPLE (max) I rms Amps at 100 KHz
SAF B	475	M	10	R 202	4.7	0.5	6	4.0	0.113
SAF C	156	M	10	R 501	15	1.5	6	2.2	0.179
SAF D2	226	M	10	R 501	22	2.2	6	1.8	0.227
SAF D2	336	M	10	R 501	33	3.3	6	1.1	0.290
SAF D	336	M	10	R 501	33	3.3	6	1.1	0.295
SAF D2	476	M	10	R 501	47	4.7	6	0.9	0.321
SAF F	476	M	10	R 401	47	4.7	6	0.9	0.343
SAF F	686	M	10	R 401	68	6.8	6	0.8	0.363

16 V DC Rated Voltage
Surge Voltage 20 VDC @ 85°C
and 13 VDC @ 125°C

SAF B	335	M	16	R 202	3.3	0.5	6	4.4	0.108
SAF C	106	M	16	R 501	10	1.6	6	2.2	0.179
SAF D2	156	M	16	R 501	15	2.4	6	1.8	0.198
SAF D2	226	M	16	R 501	22	3.5	6	1.1	0.290
SAF D	226	M	16	R 501	22	3.5	6	1.1	0.295
SAF D	336	M	16	R 501	33	5.3	6	0.9	0.327
SAF F	336	M	16	R 401	33	5.3	6	0.8	0.363
SAF F	476	M	16	R 401	47	7.5	6	0.8	0.363

20 V DC Rated Voltage
Surge Voltage 26 VDC @ 85°C
and 16 VDC @ 125°C

SAF B	225	M	20	R 202	2.2	0.5	6	5.0	0.101
SAF C	685	M	20	R 501	6.8	1.4	6	2.4	0.219
SAF D2	106	M	20	R 501	10	2.0	6	1.3	0.272
SAF D2	156	M	20	R 501	15	3.0	6	1.1	0.290
SAF D	156	M	20	R 501	15	3.0	6	1.1	0.295
SAF D	226	M	20	R 501	22	4.4	6	0.9	0.327
SAF F	226	M	20	R 401	22	4.4	6	0.8	0.363
SAF F	336	M	20	R 401	33	6.6	6	0.8	0.363

25 V DC Rated Voltage
Surge Voltage 32 VDC @ 85°C
and 20 VDC @ 125°C

SAF B	155	M	25	R 202	1.5	0.5	6	5.5	0.097
SAF C	475	M	25	R 501	4.7	1.2	6	2.4	0.171
SAF D2	685	M	25	R 501	6.8	1.7	6	1.4	0.262
SAF D2	106	M	25	R 501	10	2.5	6	1.2	0.297
SAF D	106	M	25	R 501	10	2.5	6	1.2	0.283
SAF F	156	M	25	R 401	15	3.8	6	1.0	0.325

35 V DC Rated Voltage
Surge Voltage 45 VDC @ 85°C
and 28 VDC @ 125°C

SAF B	105	M	35	R 202	1	0.5	4	6.5	0.089
SAF C	155	M	35	R 501	1.5	0.5	6	4.5	0.125
SAF C	225	M	35	R 501	2.2	0.8	6	3.5	0.142
SAF C	335	M	35	R 501	3.3	1.2	6	2.5	0.168
SAF D2	475	M	35	R 501	4.7	1.6	6	1.5	0.249
SAF D2	685	M	35	R 501	6.8	2.4	6	1.3	0.267
SAF D	685	M	35	R 501	6.8	2.4	6	1.3	0.272
SAF F	106	M	35	R 401	10	3.5	6	1.0	0.325

50 V DC Rated Voltage
Surge Voltage 63 VDC @ 85°C
and 40 VDC @ 125°C

SAF C	105	M	50	R 501	1	0.5	4	5.5	0.113
SAF C	155	M	50	R 501	1.5	0.8	6	4.0	0.152
SAF D2	225	M	50	R 501	2.2	1.1	6	2.5	0.199
SAF D2	335	M	50	R 501	3.3	1.7	6	2.0	0.215
SAF D	335	M	50	R 501	3.3	1.7	6	2.0	0.215
SAF F	475	M	50	R 401	4.7	2.4	6	1.4	0.257

NOTE: FOR 10% TOLERANCE CHANGE TOLERANCE CODE FROM M TO K.
 FOR 5% TOLERANCE CHANGE TOLERANCE CODE FROM M TO J.
 STANDARD REEL SIZE AND ORIENTATION = R. FOR OTHER SEE ORDERING INFORMATION ON PAGE 3.

Tape/Reel & Packaging Specifications

Taping Dimensions

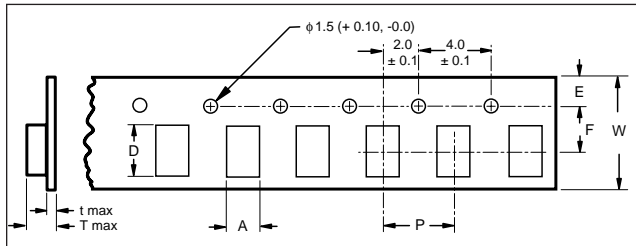

Dimensions in Millimeters

CASE CODE	A ±0.1 mm	B ±0.1 mm	W ±0.3 mm	F ±0.1 mm	E ±0.1 mm	P ±0.1 mm	Tmax	t max
R	1.6	2.4	8.0	3.5	1.75	4.0	1.7	0.2
A2	1.9	3.5	8.0	3.5	1.75	4.0	1.7	0.2
A	1.9	3.5	8.0	3.5	1.75	4.0	2.5	0.2
B2	3.1	3.9	8.0	3.5	1.75	4.0	1.7	0.2
B	3.1	3.9	8.0	3.5	1.75	4.0	2.5	0.2
H	3.1	5.1	8.0	3.5	1.75	4.0	2.5	0.2
C2	3.7	6.3	12.0	5.5	1.75	8.0	2.0	0.3
C	3.7	6.3	12.0	5.5	1.75	8.0	3.0	0.3
D2	5	6.3	12.0	5.5	1.75	8.0	3.5	0.3
D	4.8	7.7	12.0	5.5	1.75	8.0	3.4	0.3
E	4.8	7.7	12.0	5.5	1.75	8.0	5.0	0.3
F	6.3	7.7	12.0	5.5	1.75	8.0	5.0	0.3

Dimensions in Inches

CASE CODE	A ±0.004"	B ±0.004"	W ±0.012"	F ±0.004"	E ±0.004"	P ±0.004"	Tmax	t max
R	0.063	0.094	0.315	0.138	0.069	0.157	0.067	0.008
A2	0.075	0.138	0.315	0.138	0.069	0.157	0.067	0.008
A	0.075	0.138	0.315	0.138	0.069	0.157	0.098	0.008
B2	0.122	0.154	0.315	0.138	0.069	0.157	0.067	0.008
B	0.122	0.154	0.315	0.138	0.069	0.157	0.098	0.008
H	0.122	0.201	0.315	0.138	0.069	0.157	0.098	0.008
C2	0.146	0.248	0.472	0.217	0.069	0.315	0.079	0.012
C	0.146	0.248	0.472	0.217	0.069	0.315	0.118	0.012
D2	0.197	0.248	0.472	0.217	0.069	0.315	0.138	0.012
D	0.189	0.303	0.472	0.217	0.069	0.315	0.134	0.012
E	0.189	0.303	0.472	0.217	0.069	0.315	0.197	0.012
F	0.248	0.303	0.472	0.217	0.069	0.315	0.197	0.012

The surface mount tantalum capacitors are packaged in automatic insertion carrier tape.

Tape: Semi-transparent embossed plastic.

Cover tape: Polyester tape, attached by heating press

Tension for removing the cover tape: F=50g±20g

Removal Speed: 5mm/Sec

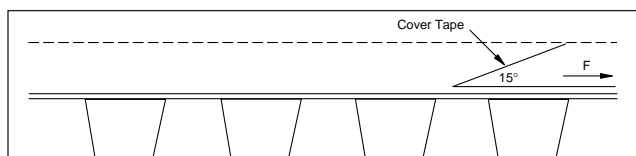

Reel and Packaging Specifications

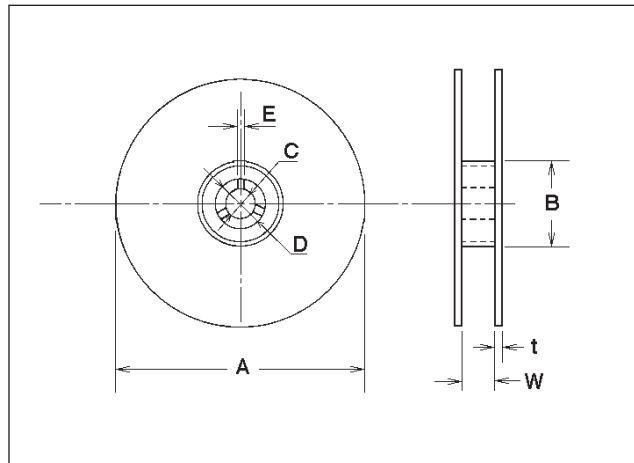

Dimensions in Millimeters

A	B	C	D	E	W	t
ø178 ±2.0	ø50 min.	13.0 ±0.5	21.0 ±0.8	2.0 ±0.8	8.8/12.8 ±1.5	2.0 ±0.5
ø330 ±2.0	ø100 min.	13.0 ±0.5	21.0 ±0.8	2.0 ±0.8	8.8/12.8 ±1.5	2.0 ±0.6

Dimensions in Inches

A	B	C	D	E	W	t
ø7 ±0.08	ø2.0 min.	5.0 ±0.02	0.83 ±0.03	0.08 ±0.3	0.35/0.50 ±0.06	0.08 ±0.02
ø13 ±0.08	ø4.0 min.	5.0 ±0.3	0.83 ±0.03	0.08 ±0.3	0.35/0.50 ±0.06	0.08 ±0.02

Reel Quantity and Quantity Codes

CASE CODE	178MM (7") REEL		330MM (13") REEL	
	QUANTITY IN PCS.	QUANTITY CODE	QUANTITY IN PCS.	QUANTITY CODE
R	3000	302	10000	103
A2	3000	302	15000	153
A	2000	202	9000	902
B2	3000	302	10000	103
B	2000	202	8000	802
H	2000	202	8000	802
C2	500	501	3000	302
C	500	501	3000	302
D2	500	501	2500	252
D	500	501	2500	252
E	400	401	1500	152
F	400	401	1500	152

SOLDERING METHODS

Solid tantalum chip capacitors can be attached by wave soldering or reflow soldering methods. The reflow soldering method however has become more popular since this process has been developed specifically for SMT components. Hand soldering is not recommended as it is not possible to control the temperature and the time the solder tip is actually in contact with the component, during the process.

7.1 WAVE SOLDERING

This process consists of creating a wave of molten solder which then comes in contact with the component and the board to make a solder joint. After placement of the chip and fixing temporarily, with suitable adhesive, the wave soldering process has the following phases:

FLUXING

This operation, performed prior to soldering, improves the solder wetting. Wetting improves as the flux deoxidizes the metal surfaces and prevents the pads and terminals from oxidation between fluxing and soldering. It also reduces the surface tension produced while in contact with the solder wave.

PREHEATING

During this operation the board is heated to about 130°C at the rate of 2°C per second. Preheating volatilizes the solvent flux carrier, takes the flux to the activation temperature and reduces the thermal shock to which the components and board are subjected, when they come into contact with the solder wave. It also increases the heat content of the board and reduces the thermal requirement of the solder wave to raise the board to the soldering temperature.

SOLDERING

This is the operation during which the solder wave comes into contact with the board and the components. A solder wave with suitable profile has to be generated to ensure sufficient flow of solder between the components with minimum solder bridges and icicles. Use of a dual wave and inclining the board at the wave 5 to 10° from the horizontal plane, are methods to improve wetting as well as reduce bridges and icicles. A typical wave soldering profile is shown in Fig. 7.1

FIGURE 7.1

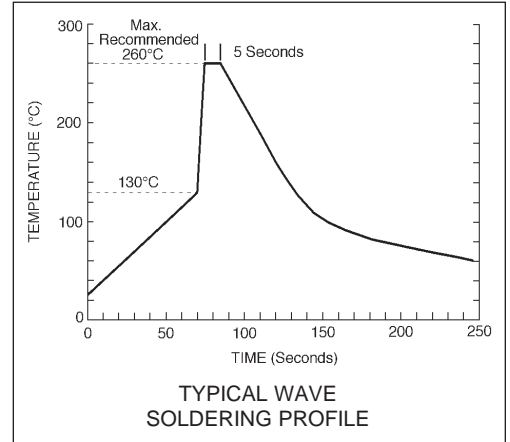

7.2 REFLOW SOLDERING

In this process solder paste is applied to the pad layout prior to placing the component. During the heating phase the solder paste melts and the reflow which takes place forms into a solder fillet. Reflow processes are classified based on the type of heating used; Infra Red reflow and Vapor Phase reflow are the commonly used reflow processes.

INFRA RED REFLOW SOLDERING

This process utilizes heat energy produced by an Infra Red radiation source to melt the solder. Tungsten tube and Nichrome tube are some of the infra red emission sources in use. Temperature of a component in an Infra Red oven is influenced by many factors such as mass of the component, density of the component, shape and size of the component, absorption coefficient of the component surface, wave length of the radiation source, time, power etc. Temperature of smaller components may reach higher temperatures if they are soldered along with larger components at the same time. Actual temperature measurements of the components are recommended as the actual temperature rise of the component cannot be precisely defined in an Infra Red oven. The temperature profile of this process is shown in Fig. 7.2

FIGURE 7.2

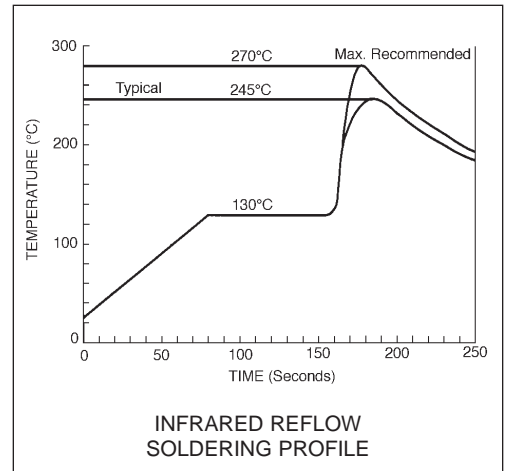

VAPOR PHASE REFLOW SOLDERING

This process utilizes a fluoro carbon liquid to transfer the heat. The fluoro carbon liquid when boiled, produces a vapor saturated atmosphere at a temperature high enough to reflow the solder. The temperature of the saturated vapor is the same as the boiling point of the liquid used and the heat transfer due to the phase change from vapor to liquid is very rapid. When the component and board reach the temperature of the vapor, condensation stops and there is no further heat flow. As condensation takes place simultaneously over the board, uniform heating is ensured. Vapor phase heating allows application of controlled heat rapidly and uniformly to complex surfaces. A standard profile of In-line Vapor phase reflow soldering process is shown in Fig. 7.3

FIGURE 7.3

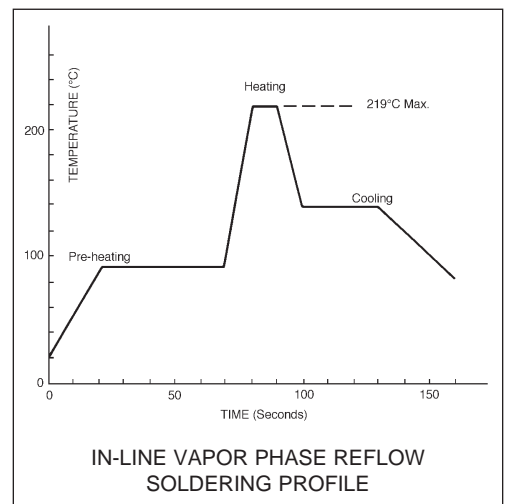

TD SERIES

INTRODUCTION

The TD Series, due to its good electrical characteristics, is recommended for professional and industrial applications. The extremely stable oxide layer of the TD solid tantalum capacitor allows only a very low leakage current even after long storage. The solid electrolyte provides stable electrical performance over wide ranges and long time periods.

FEATURES:

- HIGH TEMPERATURE RANGE OF -55 TO +125°C
- LOW LEAKAGE CURRENT AND DISSIPATION FACTOR
- COMPACT SIZE FOR SPACE SAVING DESIGN
- NO DEGRADATION EVEN AFTER PROLONGED STORAGE
- HUMIDITY, SHOCK AND VIBRATION RESISTANT SELF INSULATING ENCAPSULATION
- DECREASING FAILURE RATE INDICATING ABSENCE OF "WEAR-OUT" MECHANISM

GENERAL SPECIFICATIONS

CAPACITANCE: 0.1 μ F to 330 μ F.

VOLTAGE RANGE: 6.3VDC to 50VDC.

CAPACITANCE TOLERANCE: \pm 20%, \pm 10%, (5% upon request).

TEMPERATURE RANGE: -55°C to +125°C with Derating above 85°C as per Table 4.

DISSIPATION FACTOR: 0.1 to 1.5 μ F \leq 4%, 2.2 to 6.8 μ F \leq 6%, 10 to 68 μ F \leq 8%, >68 μ F \leq 10% at 120Hz.

LEAKAGE CURRENT: Not More Than 0.01CV μ Amps or 0.5 μ A which ever is greater.

FAILURE RATE: 1% per 1000 Hrs.

LIFE TEST DETAILS

Capacitors shall withstand rated DC Voltage applied at 85°C for 2,000 Hours. After the test:

1. Capacitance change shall not exceed \pm 10% of the initial value.
2. Dissipation factor shall be within the normal specified limits.
3. Leakage current shall be within the normal specified limit.
4. No remarkable change in the appearance. Marking shall remain legible.

TABLE 4

VOLTAGE DERATING (85°C - 125°C)

VR	6.3	10	16	20	25	35	50
VO	4	6.3	10	13	16	22	32
VS	5	8	13	16	20	28	40

VR - Rated Voltage, VO - Operating Voltage, VS - Surge Voltage

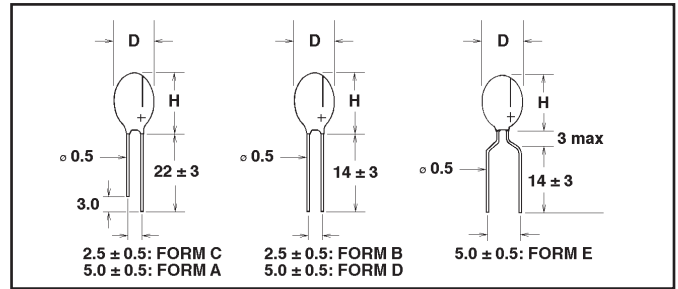

Case Dimensions TD Series

Case Code	Dimensions in mm		Dimensions in Inches	
	D max.	H max.	D max.	H max.
A	4.5	8.5	0.177	0.335
B	4.5	9.0	0.177	0.354
C	5.0	10.0	0.197	0.394
D	5.0	10.5	0.197	0.413
E	5.5	10.5	0.217	0.413
F	6.0	11.5	0.236	0.453
G	6.5	11.5	0.256	0.453
H	7.0	12.0	0.276	0.472
J	8.0	13.0	0.315	0.512
K	8.5	14.0	0.335	0.551
L	9.0	14.0	0.354	0.551
M	9.0	14.5	0.354	0.571
N	9.0	16.0	0.354	0.630
P	10.0	17.0	0.394	0.669
R	10.0	18.5	0.394	0.728

Case Codes TD Series

Capacitance		Rated Voltage V DC						
μ F	Code	6.3	10	16	20	25	35	50
0.1	104						A	A
0.15	154						A	A
0.22	224						A	A
0.33	334						A	A
0.47	474						A	A
0.68	684						A	B
1	105				A	A	A	C
1.5	155			A	A	A	A	D
2.2	225		A	A	A	A	B	E
3.3	335	A	A	A	B	B	C	F
4.7	475	A	A	B	C	C	E	G
6.8	685	A	B	C	D	D	F	H
10	106	B	C	D	E	E	F	J
15	156	C	D	E	F	F	H	K
22	226	D	E	F	H	H	K	L
33	336	E	F	F	J	J	M	
47	476	F	G	J	K	M	N	
68	686	G	H	L	N	N		
100	107	H	K	N	N			
150	157	K	N	N				
220	227	M	P					
330	337	P						



TD SERIES SPECIFICATIONS

6.3 VDC RATED VOLTAGE
 SURGE VOLTAGE 8 VDC at 85°C and 5 VDC at 125°C

PartNumber	Cap Value μ F	Cap Code	Case Size	DF % (max) @25 °C	DCL (max) μ A
TDA335K06CB	3.3	335	A	6	0.5
TDA475K06CB	4.7	475	A	6	0.5
TDA685K06CB	6.8	685	A	6	0.5
TDB106K06CB	10	106	B	8	0.5
TDC156K06CB	15	156	C	8	0.7
TDD226K06CB	22	226	D	8	1.1
TDE336K06CB	33	336	E	8	1.6
TDF476K06CB	47	476	F	8	2.3
TDG686K06CB	68	686	G	8	3.4
TDH107K06CB	100	107	H	10	5.0
TDK157K06CB	150	157	K	10	7.5
TDM227K06CB	220	227	M	10	11.0
TDP337K06CB	330	337	P	10	16.6

10 VDC RATED VOLTAGE
 SURGE VOLTAGE 13 VDC at 85°C and 8 VDC at 125°C

PartNumber	Cap Value μ F	Cap Code	Case Size	DF % (max) @25 °C	DCL (max) μ A
TDA225K10CB	2.2	225	A	6	0.5
TDA335K10CB	3.3	335	A	6	0.5
TDA475K10CB	4.7	475	A	6	0.5
TDB685K10CB	6.8	685	B	8	0.5
TDC106K10CB	10	106	C	8	0.8
TDD156K10CB	15	156	D	8	1.2
TDE226K10CB	22	226	E	8	1.7
TDF336K10CB	33	336	F	8	2.6
TDG476K10CB	47	476	G	8	3.7
TDH686K10CB	68	686	H	10	5.4
TDK107K10CB	100	107	K	10	8.0
TDN157K10CB	150	157	N	10	12.0
TDP227K10CB	220	227	P	10	17.6

16 VDC RATED VOLTAGE
 SURGE VOLTAGE 20 VDC at 85°C and 13 VDC at 125°C

PartNumber	Cap Value μ F	Cap Code	Case Size	DF % (max) @25 °C	DCL (max) μ A
TDA155K16CB	1.5	155	A	4	0.5
TDA225K16CB	2.2	225	A	6	0.5
TDA335K16CB	3.3	335	A	6	0.5
TDB475K16CB	4.7	475	B	6	0.6
TDC685K16CB	6.8	685	C	6	0.8
TDD106K16CB	10	106	D	8	1.2
TDE156K16CB	15	156	E	8	1.9
TDF226K16CB	22	226	F	8	2.8
TDF336K16CB	33	336	F	8	4.2
TDJ476K16CB	47	476	J	8	6.0
TDL686K16CB	68	686	L	10	8.7
TDN107K16CB	100	107	N	10	12.8
TDN157K16CB	150	157	N	10	19.2

20 VDC RATED VOLTAGE
 SURGE VOLTAGE 25 VDC at 85°C and 16 VDC at 125°C

PartNumber	Cap Value μ F	Cap Code	Case Size	DF % (max) @25 °C	DCL (max) μ A
TDA105K20CB	1	105	A	4	0.5
TDA155K20CB	1.5	155	A	4	0.5
TDA225K20CB	2.2	225	A	6	0.5
TDB335K20CB	3.3	335	B	6	0.5
TDC475K20CB	4.7	475	C	6	0.7
TDD685K20CB	6.8	685	D	6	1.0
TDE106K20CB	10	106	E	8	1.6
TDF156K20CB	15	156	F	8	2.4
TDH226K20CB	22	226	H	8	3.5
TDJ336K20CB	33	336	J	8	5.2
TDK476K20CB	47	476	K	8	7.5
TDN686K20CB	68	686	N	8	10.8
TDN107K20CB	100	107	N	10	16.0

25 VDC RATED VOLTAGE
 SURGE VOLTAGE 32 VDC at 85°C and 20 VDC at 125°C

PartNumber	Cap Value μ F	Cap Code	Case Size	DF % (max) @25 °C	DCL (max) μ A
TDA105K25CB	1	105	A	4	0.5
TDA155K25CB	1.5	155	A	4	0.5
TDA225K25CB	2.2	225	A	6	0.5
TDB335K25CB	3.3	335	B	6	0.6
TDC475K25CB	4.7	475	C	6	0.9
TDD685K25CB	6.8	685	D	6	1.3
TDE106K25CB	10	106	E	8	2.0
TDF156K25CB	15	156	F	8	3.0
TDH226K25CB	22	226	H	8	4.4
TDJ336K25CB	33	336	J	8	6.6
TDM476K25CB	47	476	M	8	9.4
TDN686K25CB	68	686	N	8	13.6

35 VDC RATED VOLTAGE
 SURGE VOLTAGE 44 VDC at 85°C and 28 VDC at 125°C

PartNumber	Cap Value μ F	Cap Code	Case Size	DF % (max) @25 °C	DCL (max) μ A
TDA104K35CB	0.1	104	A	4	0.5
TDA154K35CB	0.15	154	A	4	0.5
TDA224K35CB	0.22	224	A	4	0.5
TDA334K35CB	0.33	334	A	4	0.5
TDA474K35CB	0.47	474	A	4	0.5
TDA684K35CB	0.68	684	A	4	0.5
TDA105K35CB	1	105	A	4	0.5
TDA155K35CB	1.5	155	A	4	0.5
TDB225K35CB	2.2	225	B	6	0.6
TDC335K35CB	3.3	335	C	6	0.9
TDE475K35CB	4.7	475	E	6	1.3
TDF685K35CB	6.8	685	F	6	1.9
TDF106K35CB	10	106	F	8	2.8

35 VDC RATED VOLTAGE (Continued)
 SURGE VOLTAGE 44 VDC at 85°C and 28 VDC at 125°C

PartNumber	Cap Value μ F	Cap Code	Case Size	DF % (max) @25 °C	DCL (max) μ A
TDH156K35CB	15	156	H	8	4.2
TDK226K35CB	22	226	K	8	6.1
TDM336K35CB	33	336	M	8	9.2
TDN476K35CB	47	476	N	8	10.0

50 VDC RATED VOLTAGE
 SURGE VOLTAGE 63 VDC at 85°C and 40 VDC at 125°C

PartNumber	Cap Value μ F	Cap Code	Case Size	DF % (max) @25 °C	DCL (max) μ A
TDA104K50CB	0.1	104	A	4	0.5
TDA154K50CB	0.15	154	A	4	0.5
TDA224K50CB	0.22	224	A	4	0.5
TDA334K50CB	0.33	334	A	4	0.5
TDA474K50CB	0.47	474	A	4	0.5
TDB684K50CB	0.68	684	B	4	0.5
TDC105K50CB	1	105	C	4	0.5
TDD155K50CB	1.5	155	D	4	0.6
TDE225K50CB	2.2	225	E	6	0.8
TDF335K50CB	3.3	335	F	6	1.3
TDG475K50CB	4.7	475	G	6	1.8
TDH685K50CB	6.8	685	H	6	2.7
TDJ106K50CB	10	106	J	8	4.0
TDK156K50CB	15	156	K	8	6.0
TDL226K50CB	22	226	L	8	8.8

Note: Part numbers indicated are for 10% tolerance parts with straight uneven leads and 2.5mm lead spacing. Please refer to ordering information for details of other tolerances and lead styles.